

PROJECT 3 : WATER TANK CONTROLLING SYSTEM

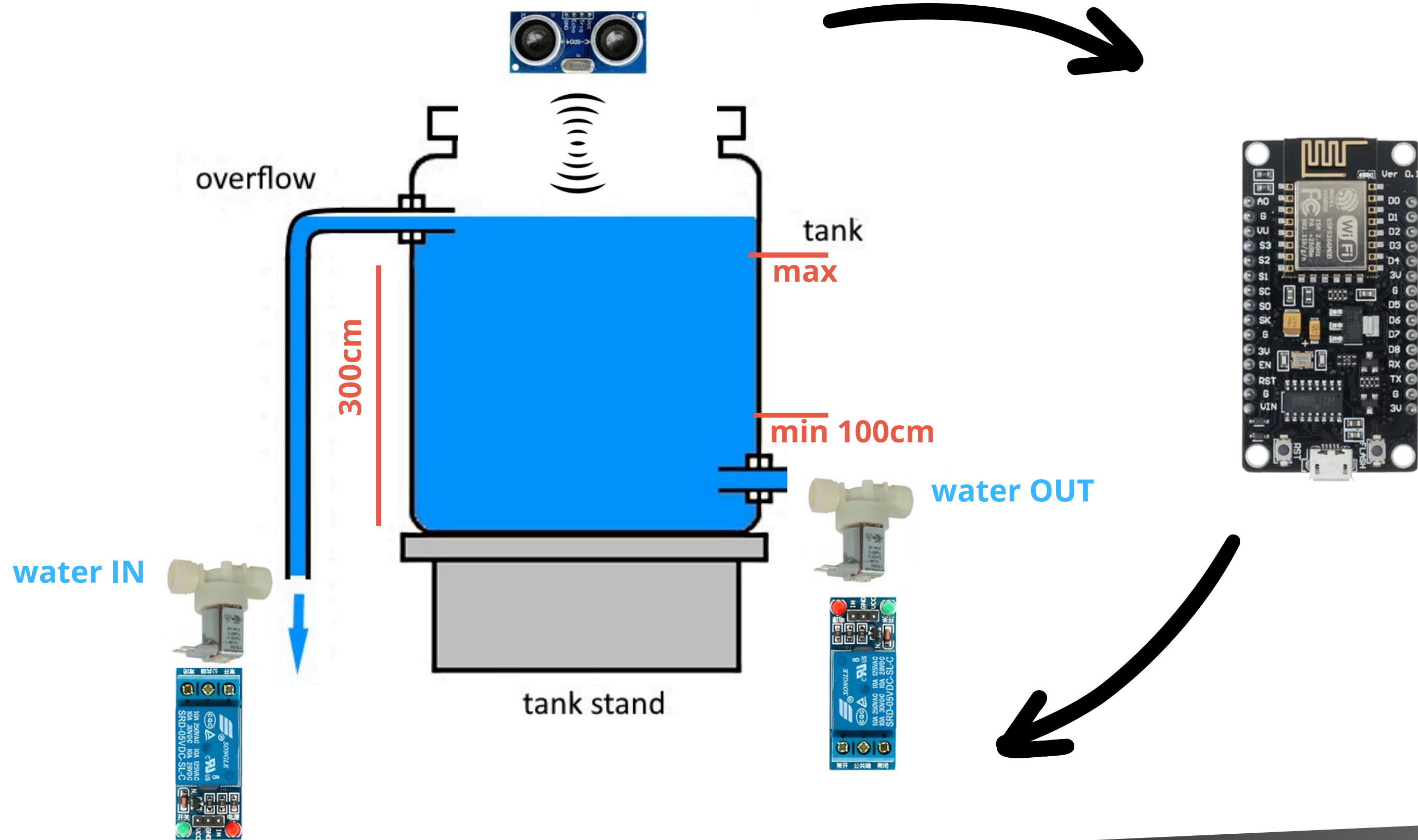

MATERIALS



HC-St04 ultrasonic sensor



relay module



ESP32



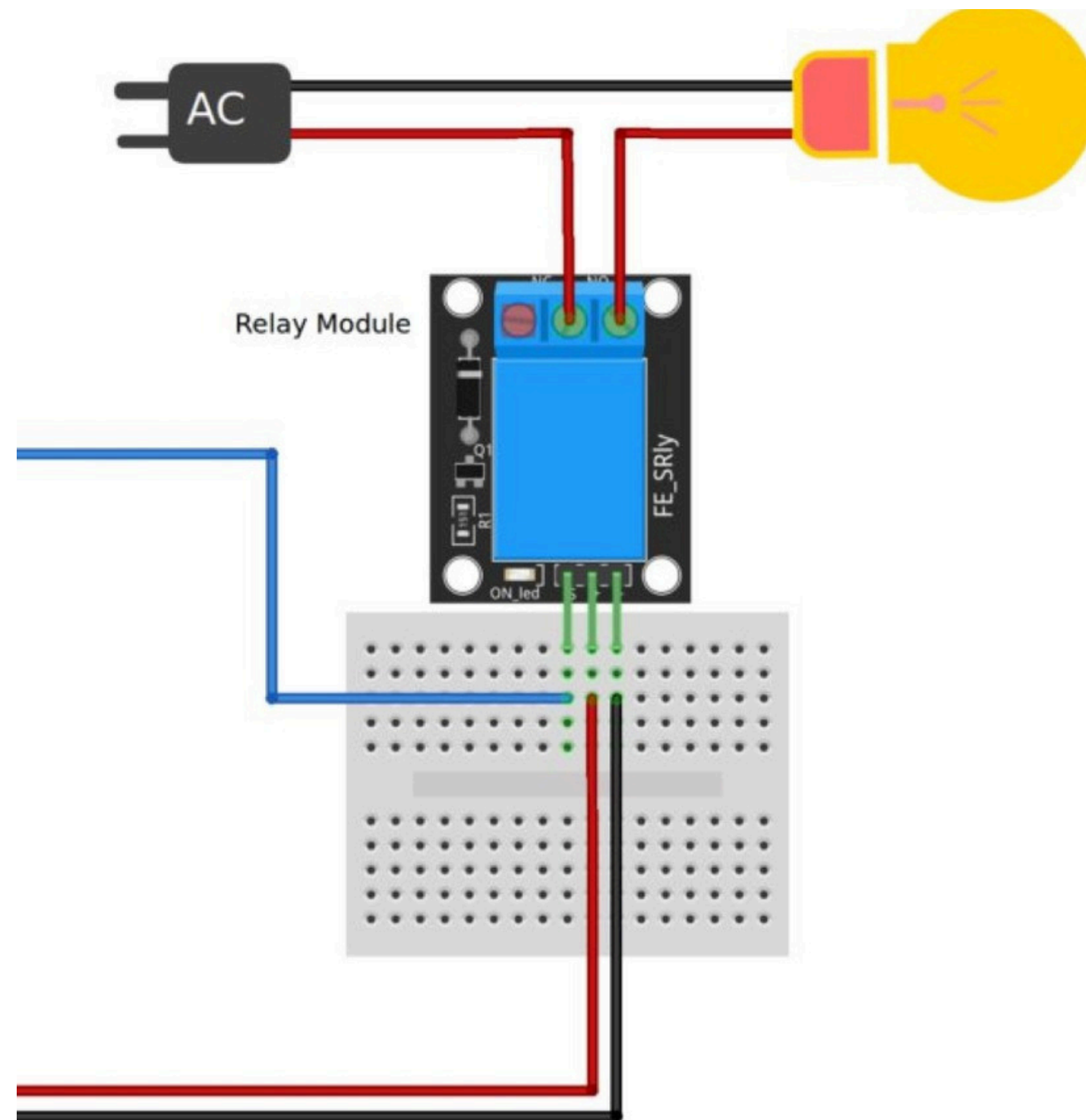

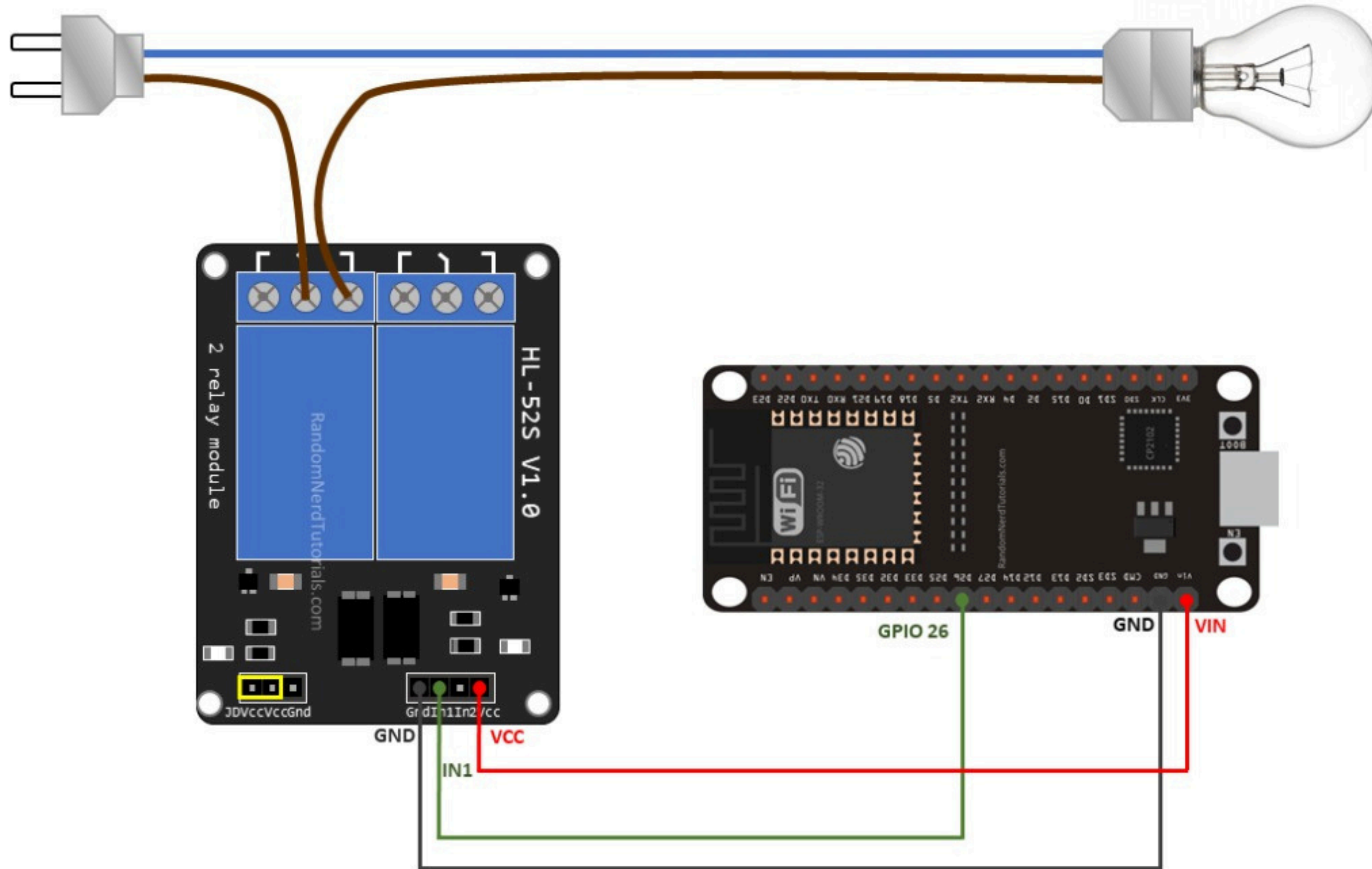

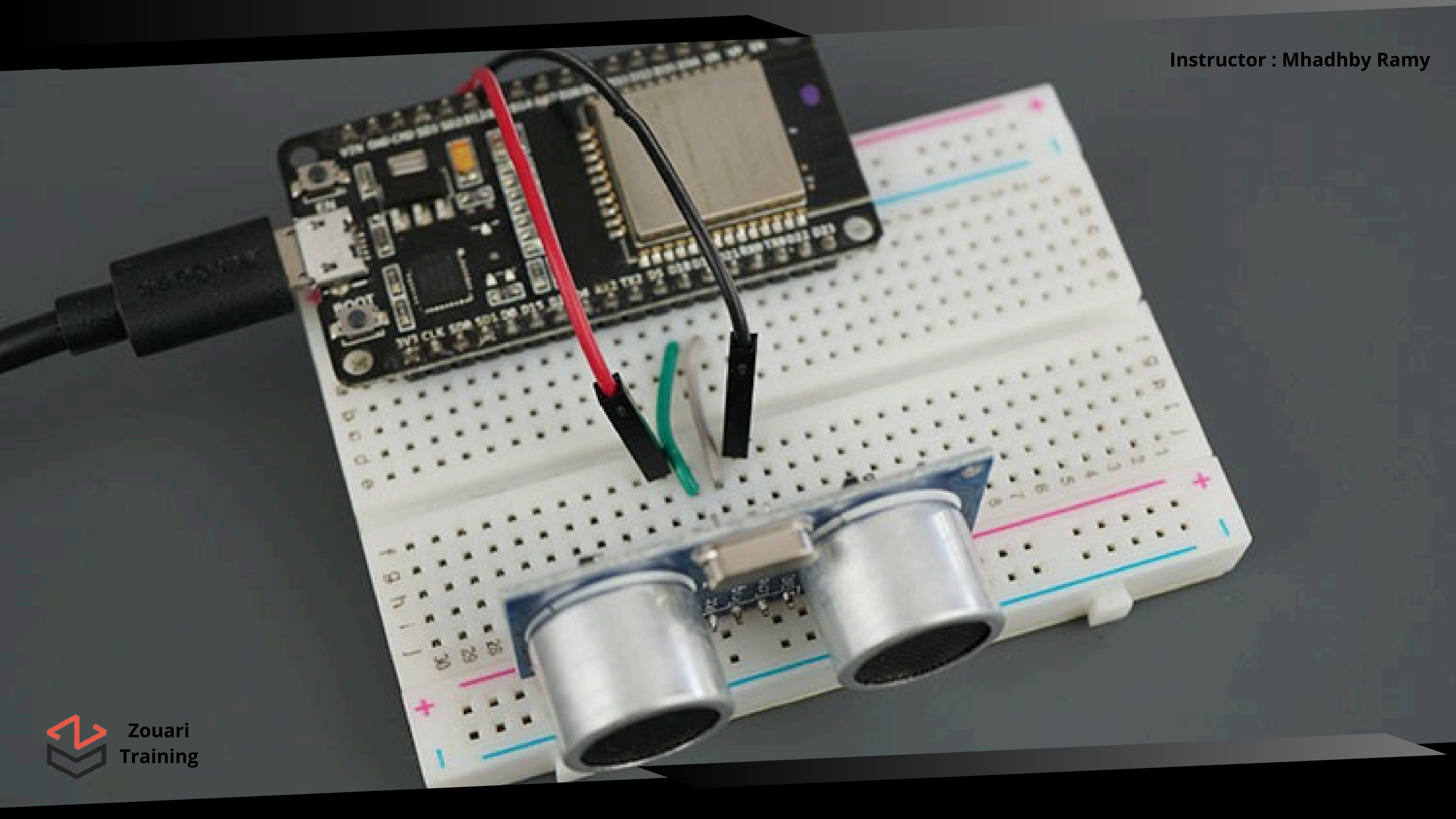

ULTRASONIC SENSOR



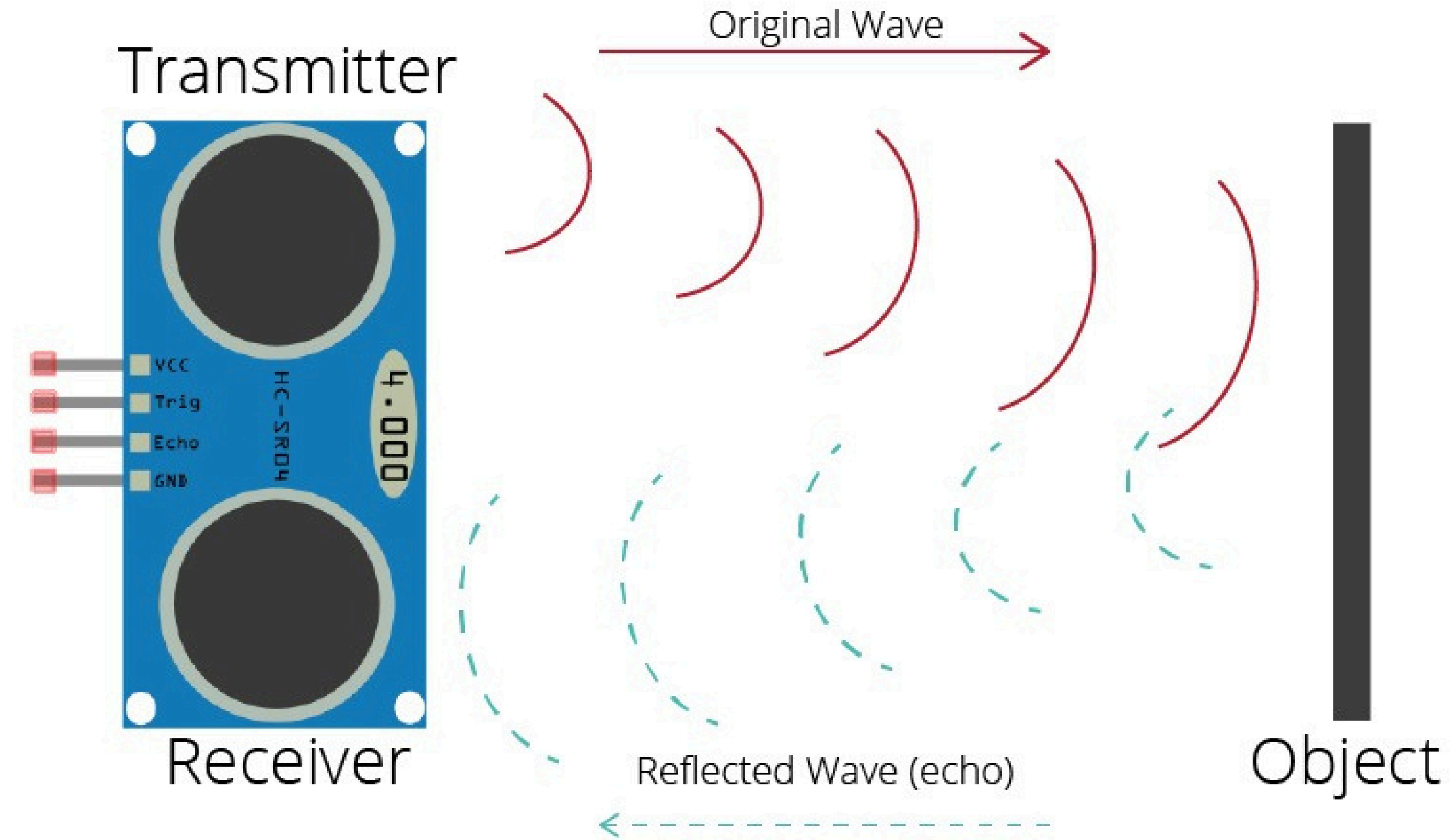

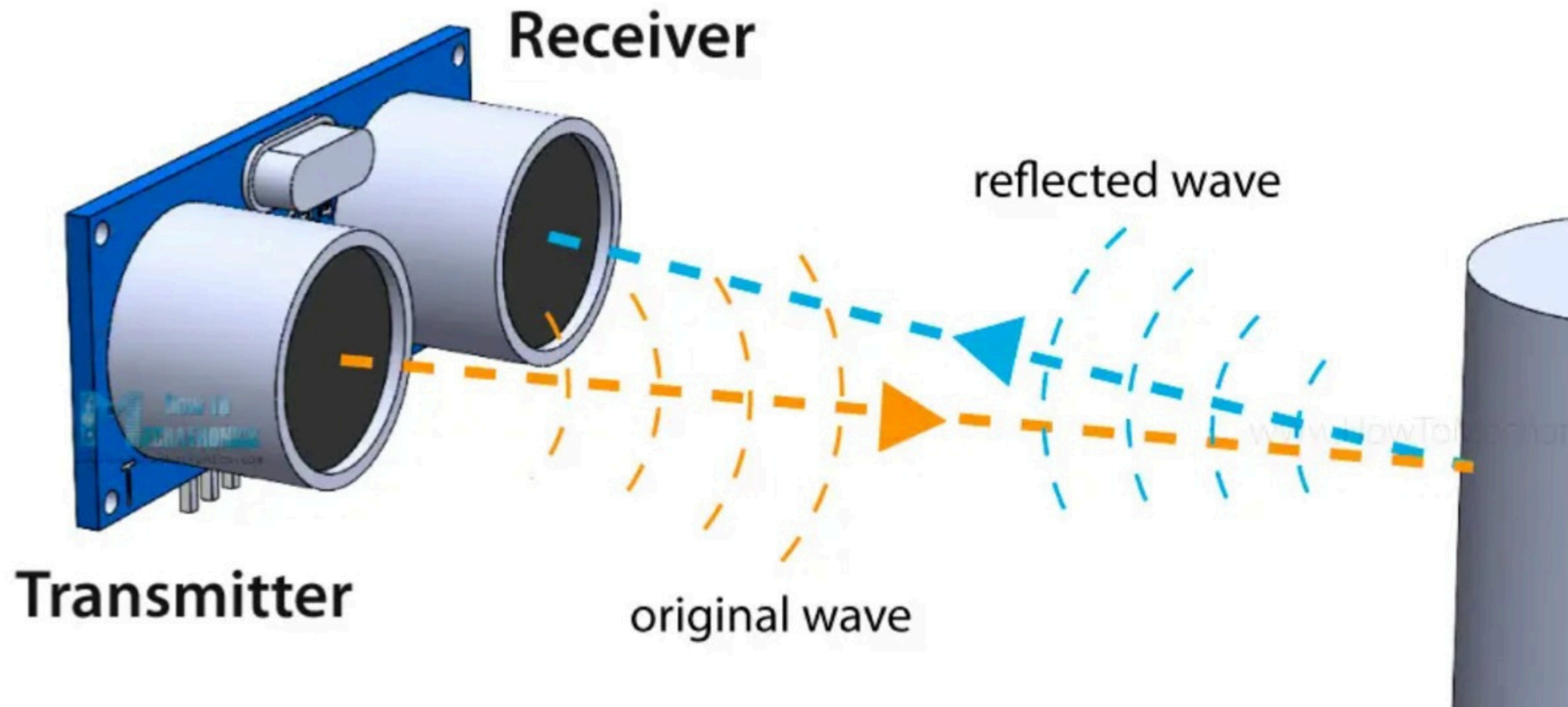

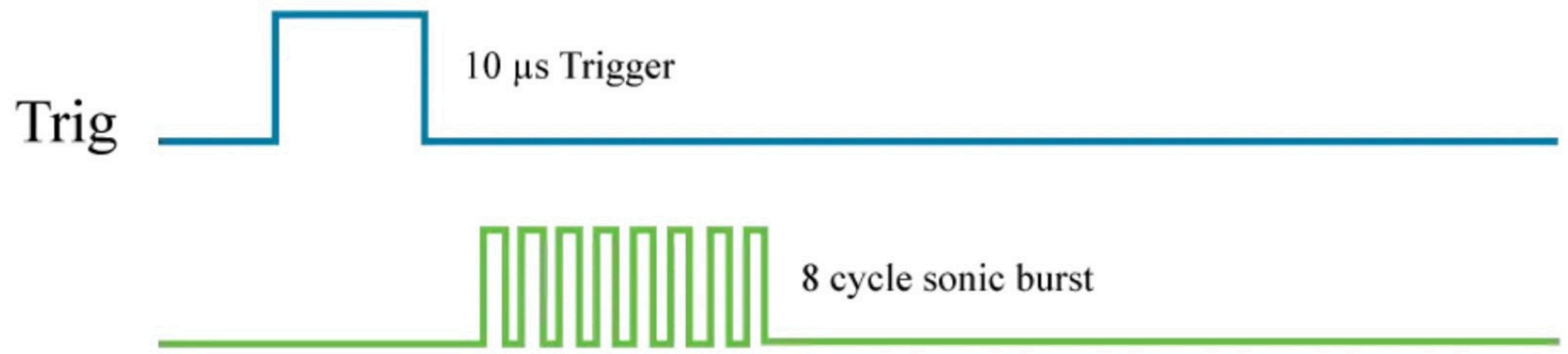

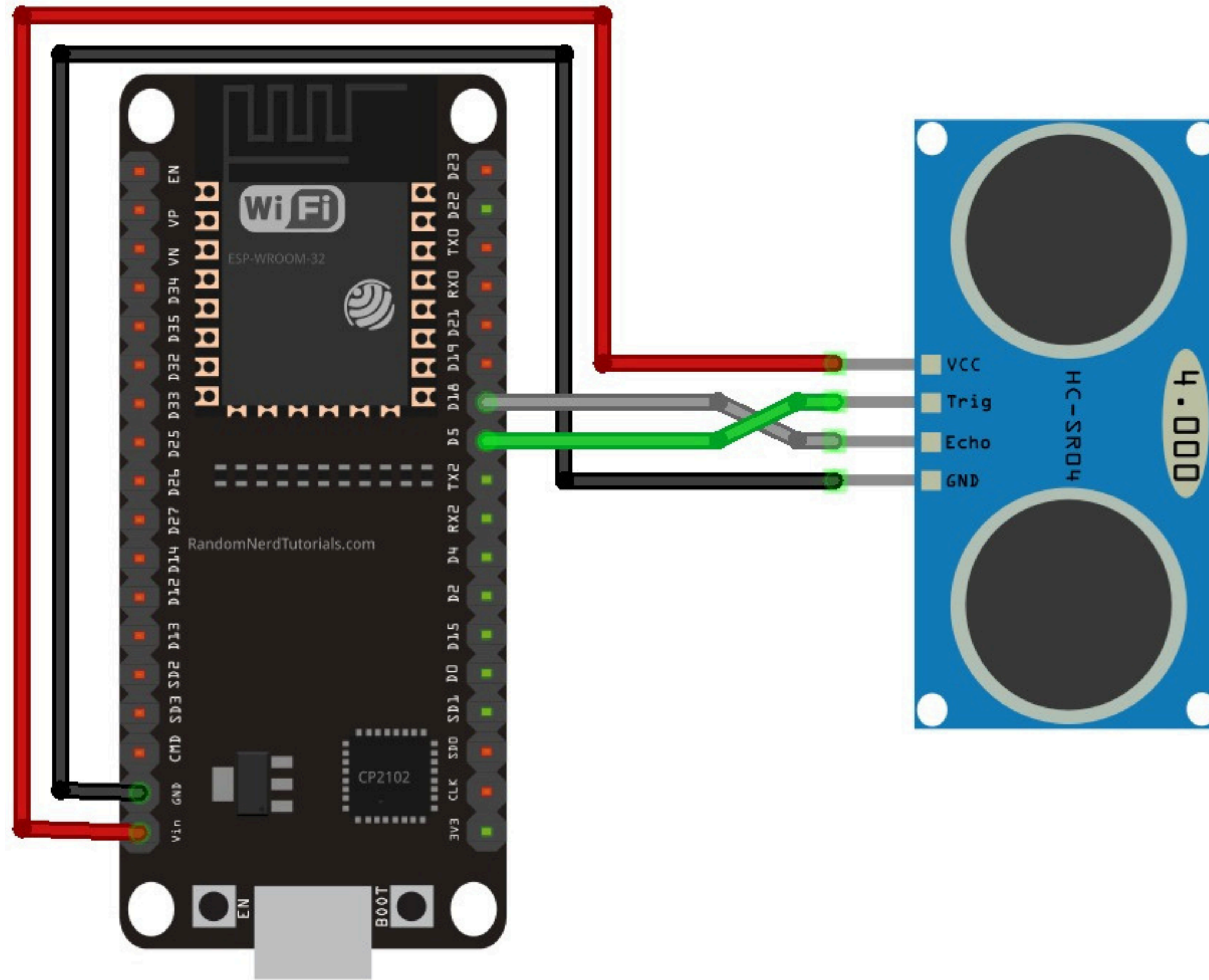

EXERCICE

Réaliser un générateur de son avec un **buzzer**, un **capteur ultrasonique** et une **diode LED**, où l'intervalle de temps entre les bips du buzzer et le clignotement de la diode LED varie de **0 à 1 seconde**, en fonction de la distance mesurée dans une plage de **0 à 100 cm**